





-  Electrically heated
-  Water heated

CE

Thermozone® SF

Air curtains for vertical mounting in curved doorways

Thermozone SF is an ideal solution for any environment with revolving doors or curved sliders. The air curtain is mounted vertically and its curved design integrates neatly with the door. Thermozone SF efficiently protects the exposed area just above the floor.

The revolving door is a very efficient solution in buildings where the wind stress and pressure difference over the entrance is high. Although the revolving door prevents the stream of cold air entering the building it brings cold air with every turn.

Thermozone SF prevents the cold air from leaving the revolving doors, providing good heating comfort and the opportunity to make use of the floor space close to the opening.

The air curtain can also contribute to heating the entrance.

When it is hot outside, the Thermozone SF prevents warm air from getting in and cold, conditioned air from being lost.

Thermozone SF also gives protection from fumes and dust - and has a drying effect on the area within and around the revolving doors.

- Thermozone SF represents an overall solution for revolving doors and curved sliders.
- Curved design that integrates neatly with the door.
- Highest output in the exposed area just above the floor.
- A specially designed inlet grille protects the heating coil and makes a dust filter superfluous.
- Standard length 2200 mm. Extension possible up to 3900 mm (extension without fans).
- To make the installation quicker and more compact, valves are integrated in the unit.
- Easy connection of water heated units with flexible hoses.
- Corrosion proof housing made of zinc-plated steel panels. Two-pack coating (any RAL/NCS colour) is standard. Powder coating (any RAL/NCS colour) or stainless steel are optional.

CE-compliant.

This product is sold and serviced by:



For contact details, see www.besam.com.

Technical specifications | Thermozone SF 2200 E with electrical heat



Type	Output stages	Airflow [m³/h]	Sound level*1 [dB(A)]	Δt *2 [°C]	Voltage [V]	Voltage [V]	Length [mm]	Weight [kg]
	[kW]				Amperage [A] (control)	Amperage [A] (heat)		
SF1-2200E12	8/12	1800	55	20	230V~/2,52A	400V3~/17,5A	2200 ^{*3}	110
SF2-2200E12	8/12	2400	56	15	230V~/3,36A	400V3~/17,5A	2200 ^{*3}	116
SF3-2200E18	12/18	3600	57	15	230V~/4,48A	400V3~/26A	2200 ^{*3}	122
SF-SOBM2200E18	12/18	3600	56	15	230V~/4,20A	400V3~/26A	2200 ^{*3}	108
SF-SOBG2200E30	20/30	5400	57	17	230V~/6,72A	400V3~/43,5A	2200 ^{*3}	110

Technical specifications | Thermozone SF 2200 W with water heat



Type	Output*4	Airflow [m³/h]	Sound level*1 [dB(A)]	Δt *2 [°C]	Voltage [V]	Amperage [A]	Length [mm]	Weight [kg]
	[kW]							
SF1-2200WL	9	1800	55	15	230V~	2,52	2200 ^{*3}	110
SF2-2200WL	12	2400	56	15	230V~	3,36	2200 ^{*3}	116
SF3-2200WL	19	3600	57	16	230V~	4,48	2200 ^{*3}	122
SF-SOBM2200WL	21	3600	56	17	230V~	4,20	2200 ^{*3}	108
SF-SOBG2200WL	26	5400	57	14	230V~	6,72	2200 ^{*3}	110

*1) Conditions: Distance to the unit 3 metres. Equivalent absorption area 500 m².

*2) Δt = temperature rise of passing air at maximum heat output and highest airflow.

*3) Extension possible up to 3900 mm (extension without fans).

*4) Applicable at water temperature 60/40°C, air temperature 20°C.



Ordering

Order selections

Type	See Compatibility table.
Version	Electrically heated (E) or water heated (WL).
Connections position	From below (1) or above (2), see fig. 1.
Total height	Extension possible up to 3900 mm. Extension without fans. Units higher than 3000 mm are delivered in two pieces. Min. height 2200 mm.
Finish / Material	Coating or stainless steel, see table.

Compatibility Besam door and Frico air curtain

Revolving door		Without sliding door	
Besam door	Frico air curtain	Besam door	Frico air curtain
RD-3-18	SF1-2200	UniTum 36	SF1-2200
RD-3-21	SF1-2200	UniTum 42	SF2-2200
RD-3-24	SF1-2200	UniTum 48	SF2-2200
RD-3-27	SF1-2200	UniTum 54	SF3-2200
RD-3-30	SF1-2200		
RD-3-36	SF1-2200		
		With sliding door	
Besam door	Frico air curtain	Besam door	Frico air curtain
RD-4-18	SF1-2200	UniTum 36	SF-SOBM2200
RD-4-21	SF1-2200	UniTum 42	SF-SOBM2200
RD-4-24	SF1-2200	UniTum 48	SF-SOBG2200
RD-4-27	SF1-2200	UniTum 54	SF-SOBG2200
RD-4-30	SF1-2200		
RD-4-36	SF2-2200		

Finish / Material selection

Two-pack coating (standard)	State RAL/NCS code
Powder coating RAL	State RAL code
Powder coating NCS	State NCS code
Stainless steel	Cr-Ni Grinded K 240
Stainless steel	Cr-Ni Brushed 316
Stainless steel	Cr-Ni Bright annealed
Stainless steel	Cr-Ni Mirror no 8

Connections position

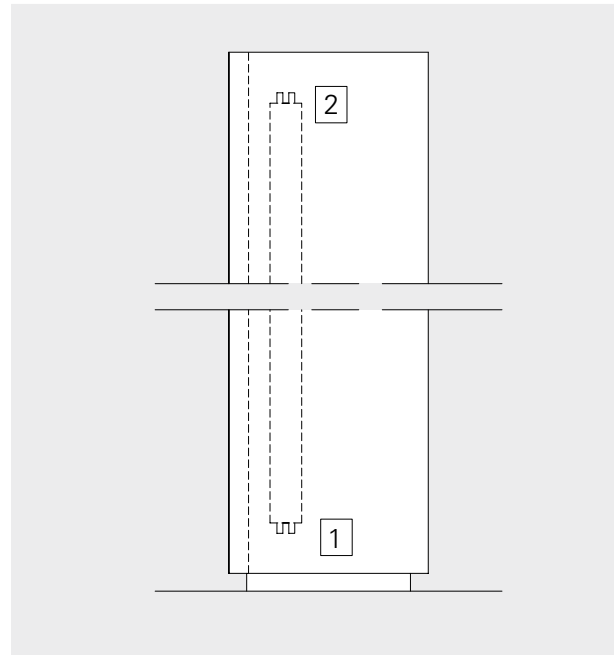
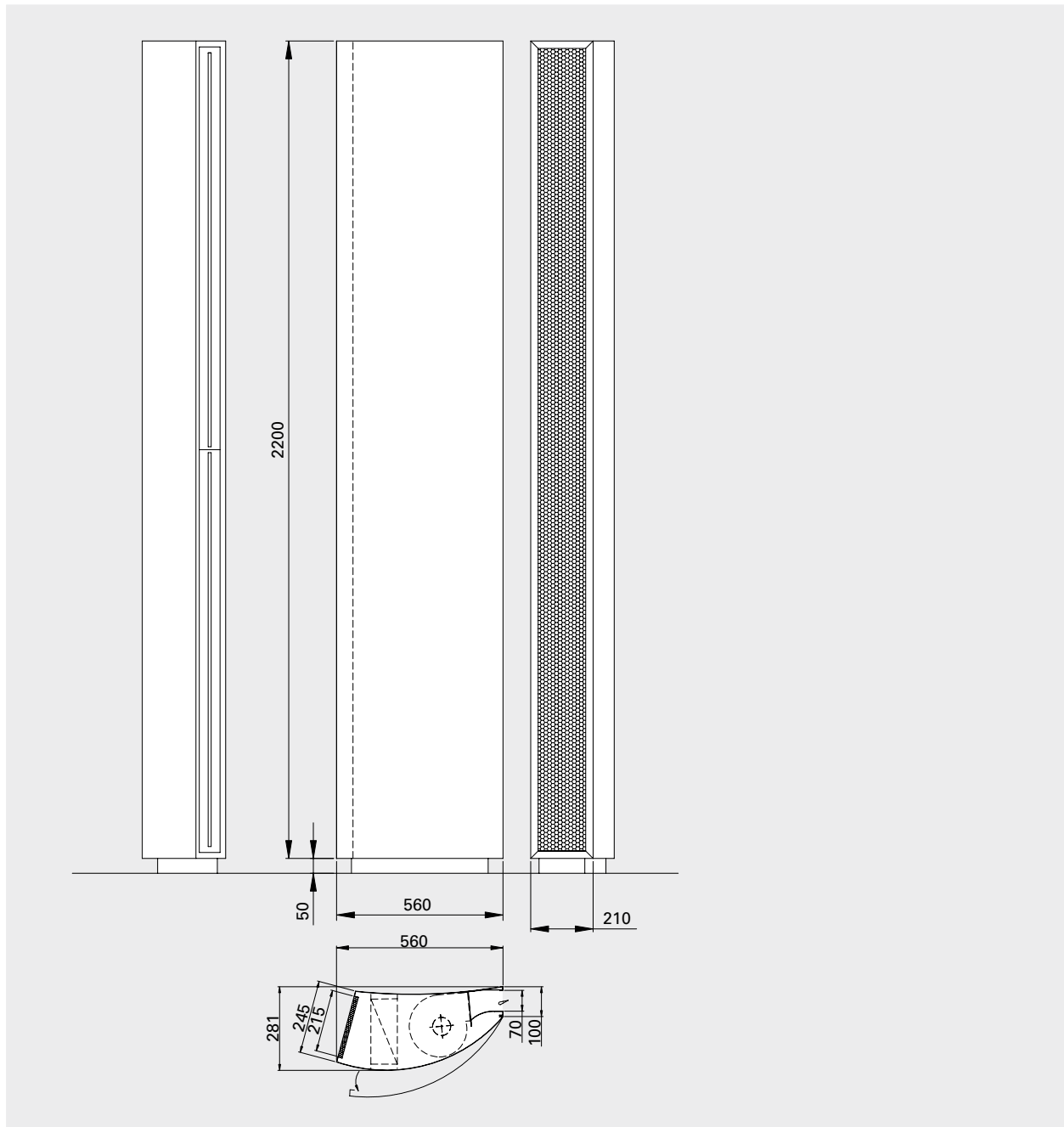

Fig. 1 From below (1) or above (2), inside connection

Dimensions



Mounting and installation

The floor-standing SF unit is mounted on adjustable feet that make it possible to compensate for possible irregularities in the floor. The feet are bolted to the floor and covered by a covering edge. SF is mounted to the left of the door seen from inside the building and should also be secured to the door.

Two flexible hoses (1" inside thread) are included on delivery for easy connection to existing pipe system. Length 1 m.

Regulation kits

Electrical ⚡

Airflow and heat output are controlled automatically based on the opening of the door and the room temperature.

When the door is open the fan runs on high speed, when the door closes the fan will continue to run for the desired time (2s–10 min.) set on MDC. When the door is closed the fan runs on low speed if there is a need for heating, if not the fan is switched off.

The room thermostat controls the heat output. E.g. the thermostat is set on 23°C and the difference between the stages 4°C. The thermostat will activate below 19°C when the door is closed. When the door opens, the thermostat will activate below 23°C and normally the heat is switched on.

Complete regulation kit:

- CB32N, control box, controls the airflow in 3 stages and heat output in 2 stages
- MDC, door contact with time delay
- RTI2, electronic 2-stage thermostat (option KRT2800)

Water 💧

Airflow and heat output are controlled automatically based on the opening of the door and the room temperature.

When the door is open the fan runs on high speed, when the door closes the fan will continue to run for the desired time (2s–10 min.) set on MDC. When the door is closed the fan runs on low speed if there is a need for heating, if not the fan is switched off.

The room thermostat controls the heat output. E.g. the thermostat is set on 23°C and the difference between the stages 4°C. The thermostat will activate below 19°C when the door is closed. When the door opens, the thermostat will activate below 23°C and normally the heat is switched on.

Complete regulation kit:

- CB30N, control box, controls the air flow in 3 stages
- MDC, door contact with time delay
- RTI2, electronic 2-stage thermostat (option KRT2800)
- Three-way motor valve with actuator and by-pass valve are integrated in the unit.

Output charts water

SF 2200WL

Incoming / outgoing water temperature 80/60°C								
Type	Fan position	Airflow [m³/h]	Incoming air temp.= +15°C			Incoming air temp. = +20°C		
			Output [kW]	Outgoing air temp. [°C]	Water flow [l/s]	Output [kW]	Outgoing air temp. [°C]	Water flow [l/s]
SF1-2200WL	max	1800	18,0	45	0,22	16,4	47	0,20
	min	900	11,0	51	0,13	10,0	53	0,12
SF2-2200WL	max	2400	23,5	44	0,29	21,3	46	0,26
	min	1200	14,4	51	0,18	13,1	52	0,16
SF3-2200WL	max	3600	37,9	46	0,46	34,3	48	0,42
	min	1800	23,0	53	0,28	20,9	55	0,26
SF-SOBM2200WL	max	3600	30,6	40	0,38	27,7	43	0,34
	min	1800	19,4	47	0,24	17,5	49	0,21
SF-SOBG2200WL	max	5400	49,2	42	0,60	44,5	45	0,54
	min	2700	30,9	49	0,38	28,0	51	0,34

Incoming / outgoing water temperature 60/50°C								
Type	Fan position	Airflow [m³/h]	Incoming air temp.= +15°C			Incoming air temp. = +20°C		
			Output [kW]	Outgoing air temp. [°C]	Water flow [l/s]	Output [kW]	Outgoing air temp. [°C]	Water flow [l/s]
SF1-2200WL	max	1800	13,3	37	0,32	11,6	39	0,28
	min	900	8,0	42	0,19	7,0	43	0,17
SF2-2200WL	max	2400	17,3	36	0,42	15,1	39	0,37
	min	1200	10,6	41	0,26	9,2	43	0,22
SF3-2200WL	max	3600	27,7	38	0,67	24,2	40	0,59
	min	1800	16,9	43	0,41	14,8	44	0,36
SF-SOBM2200WL	max	3600	22,5	34	0,54	19,6	36	0,48
	min	1800	14,1	39	0,34	12,3	40	0,30
SF-SOBG2200WL	max	5400	36,4	35	0,88	31,7	38	0,77
	min	2700	22,7	40	0,55	19,8	42	0,48

Incoming / outgoing water temperature 60/40°C								
Type	Fan position	Airflow [m³/h]	Incoming air temp.= +15°C			Incoming air temp. = +20°C		
			Output [kW]	Outgoing air temp. [°C]	Water flow [l/s]	Output [kW]	Outgoing air temp. [°C]	Water flow [l/s]
SF1-2200WL	max	1800	10,9	33	0,13	9,2	35	0,11
	min	900	6,8	37	0,08	5,7	39	0,07
SF2-2200WL	max	2400	14,3	33	0,17	12,0	35	0,14
	min	1200	8,9	37	0,11	7,5	39	0,09
SF3-2200WL	max	3600	22,8	34	0,28	19,1	36	0,23
	min	1800	14,0	38	0,17	11,9	40	0,14
SF-SOBM2200WL	max	3600	18,5	30	0,23	15,5	33	0,19
	min	1800	11,8	35	0,14	9,9	36	0,12
SF-SOBG2200WL	max	5400	29,5	31	0,36	24,8	34	0,30
	min	2700	18,8	36	0,23	15,8	37	0,19

Incoming / outgoing water temperature 60/30°C								
Type	Fan position	Airflow [m³/h]	Incoming air temp.= +15°C			Incoming air temp. = +20°C		
			Output [kW]	Outgoing air temp. [°C]	Water flow [l/s]	Output [kW]	Outgoing air temp. [°C]	Water flow [l/s]
SF1-2200WL	max	1800	8,2	29	0,07	6,1	30	0,05
	min	900	4,5	30	0,04	2,7	29	0,02
SF2-2200WL	max	2400	10,8	28	0,09	8,4	30	0,07
	min	1200	6,8	32	0,06	4,6	32	0,04
SF3-2200WL	max	3600	17,0	29	0,14	12,7	30	0,10
	min	1800	9,3	30	0,08	5,1	29	0,04
SF-SOBM2200WL	max	3600	13,9	27	0,11	10,7	29	0,09
	min	1800	9,0	30	0,07	7,0	32	0,06
SF-SOBG2200WL	max	5400	21,9	27	0,18	16,7	29	0,13
	min	2700	14,2	31	0,11	8,1	29	0,07

Pressure drop water

Water pressure drop over SFW water coil

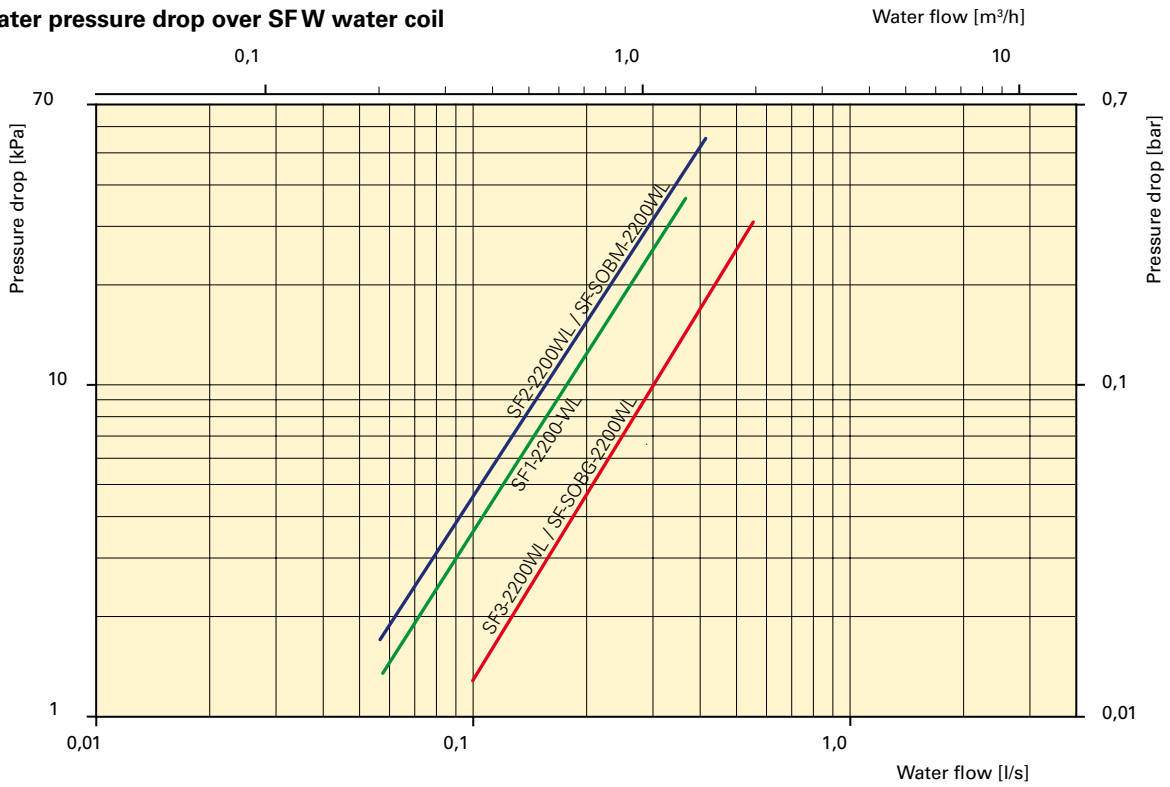

Water pressure drop over controls and valves

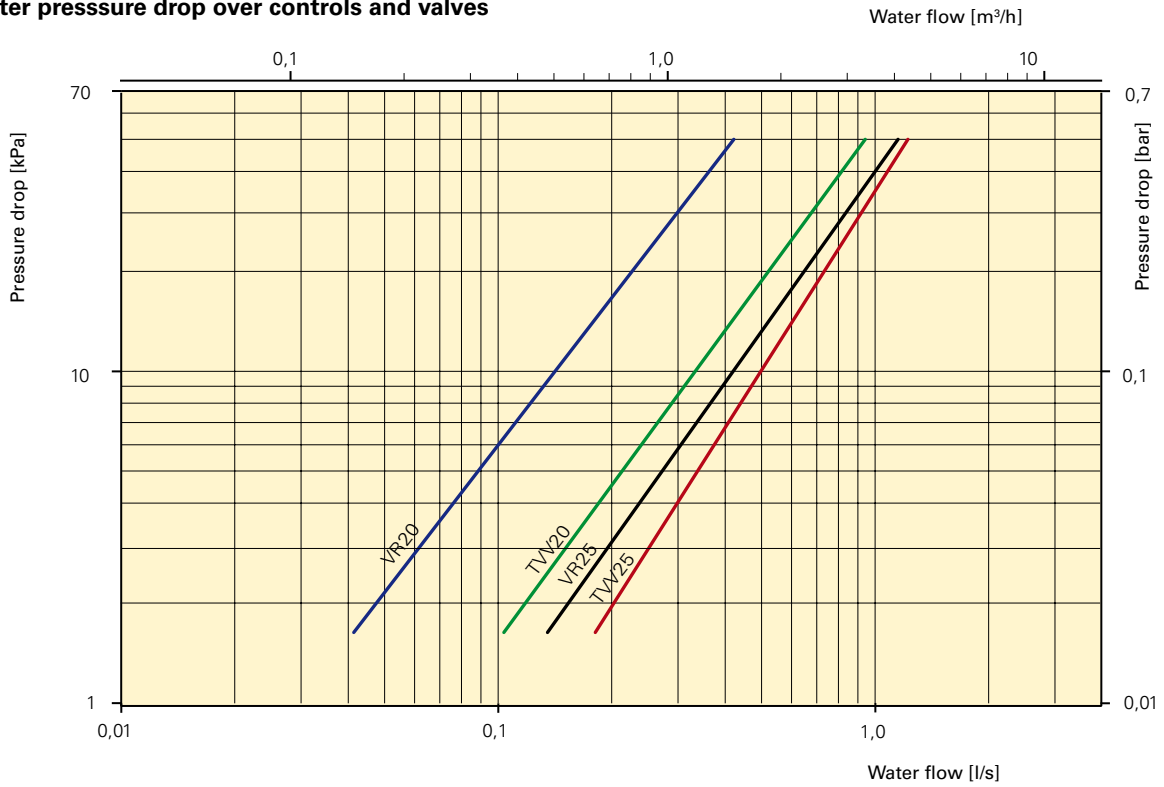

The pressure drop is calculated for an average temperature of 70°C (PVV 80/60).
 For other water temperatures, the pressure drop is multiplied by the factor K.

Average temp. water °C	40	50	60	70	80	90
K	1,10	1,06	1,03	1,00	0,97	0,93

Wiring diagrams SF E

Electrical control options

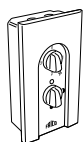
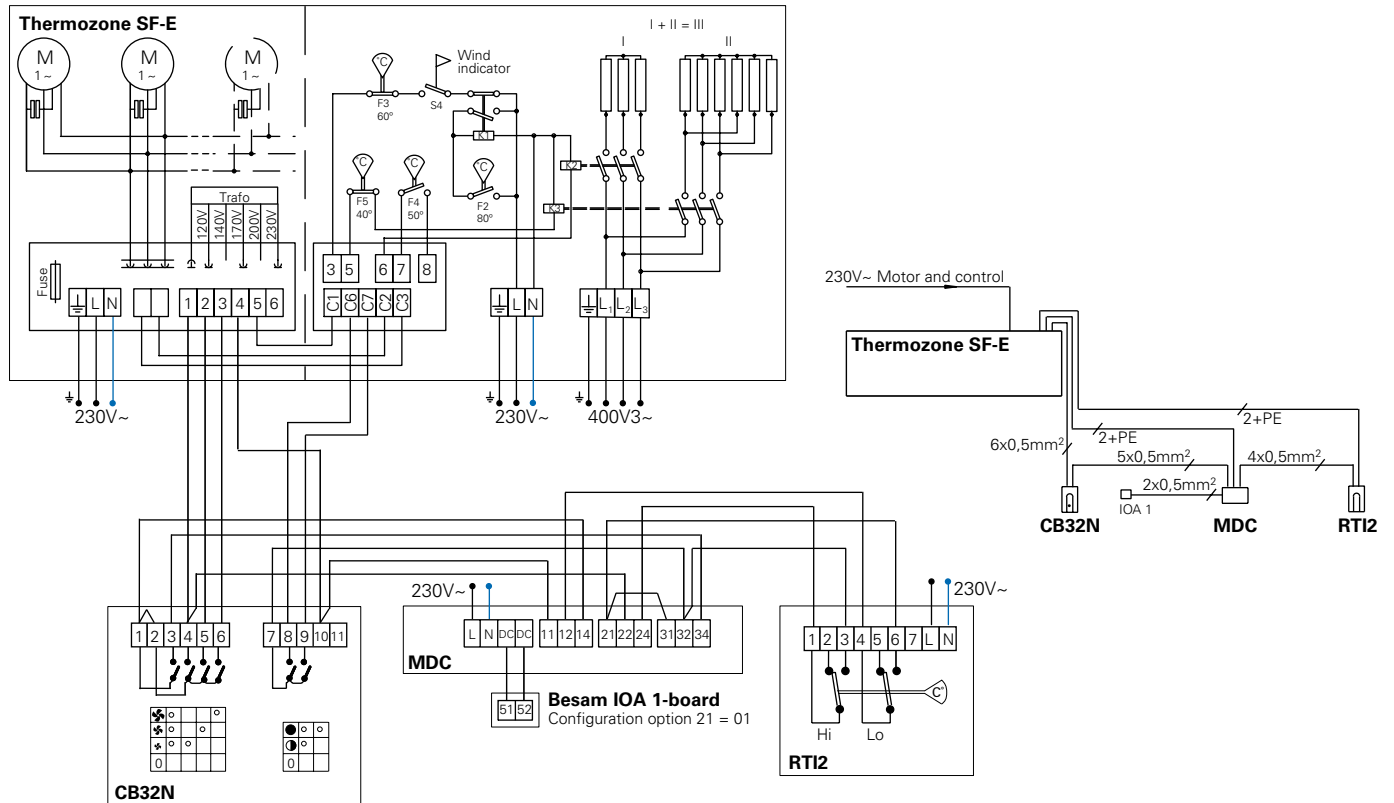

CB32N, control box

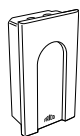

RT12, electronic 2-stage thermostat



MDC, magnetic door contact with time delay

Thermozone SF

Wiring diagrams SFW

Water control options

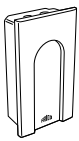
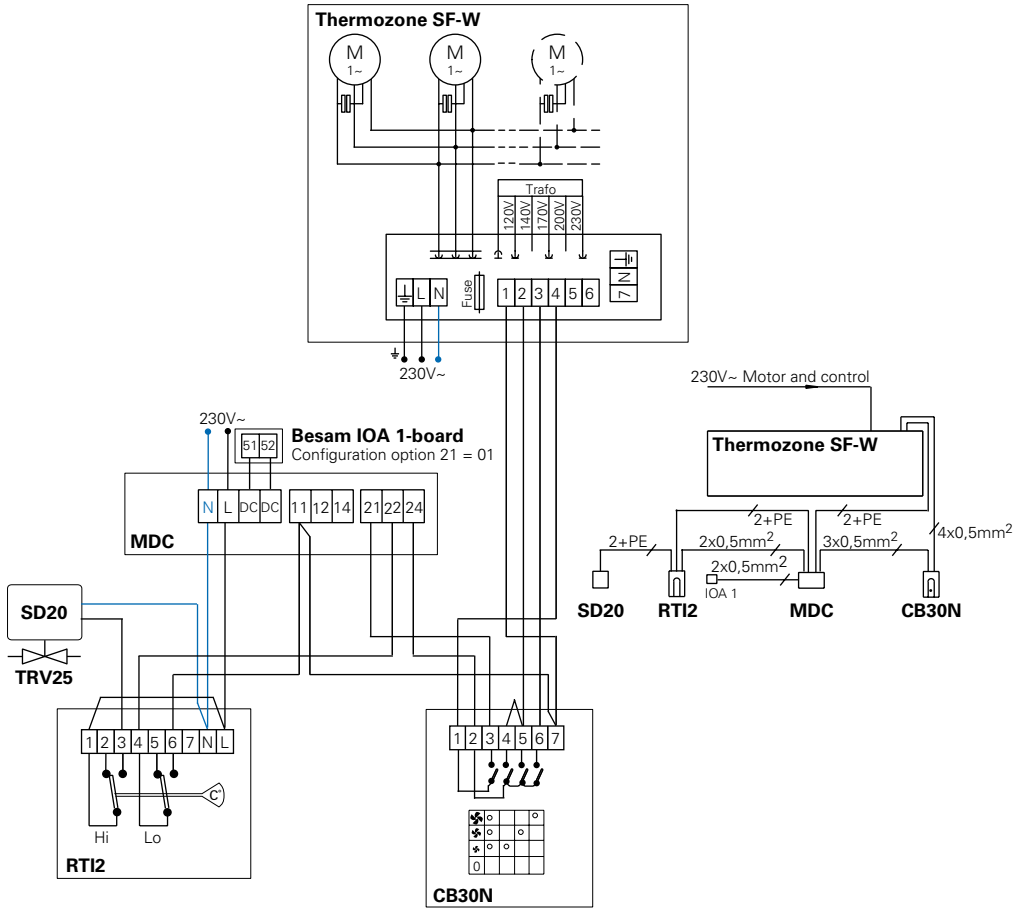

RTI2, electronic 2-stage thermostat

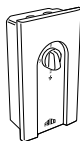

CB30N, control box



MDC, magnetic door contact with time delay

Integrated valves

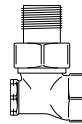

BPV10

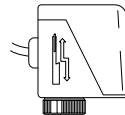

SD20

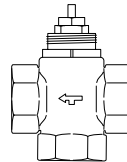

TRV25